

Indaver Rivenhall IWMF DCO

Planning Act 2008

Infrastructure Planning (Applications: Prescribed Forms and Procedure)

Regulations 2009

PLANS [PINS Ref: EN0101038] ILLUSTRATIVE PLAN

Document Reference: EN0101038/APP/2.6

Revision Number 1.0

APFP Regulation 5(2)(o)

November 2023

Indaver Rivenhall Ltd

Leading the field in
sustainable waste
management.

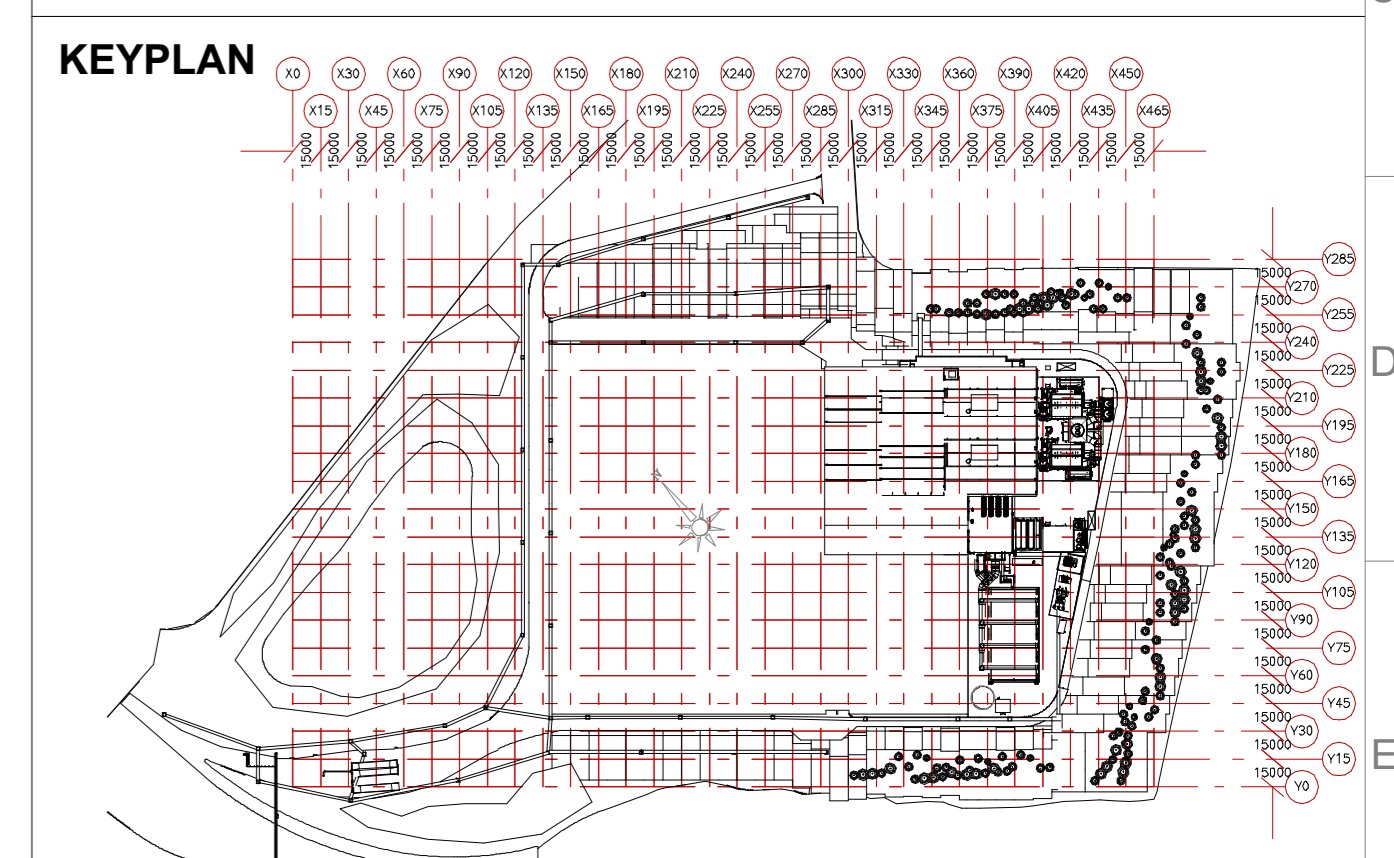
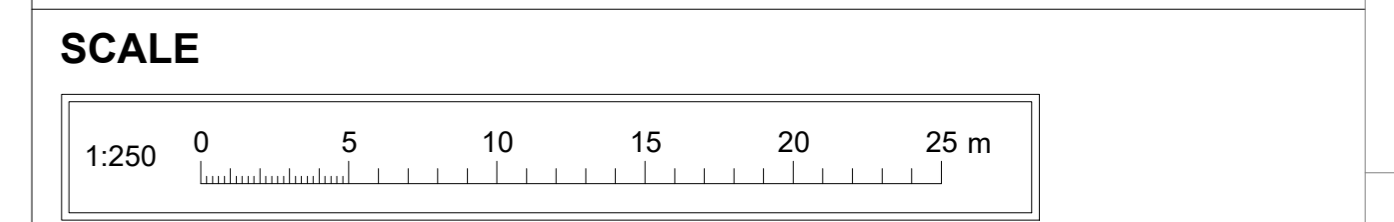
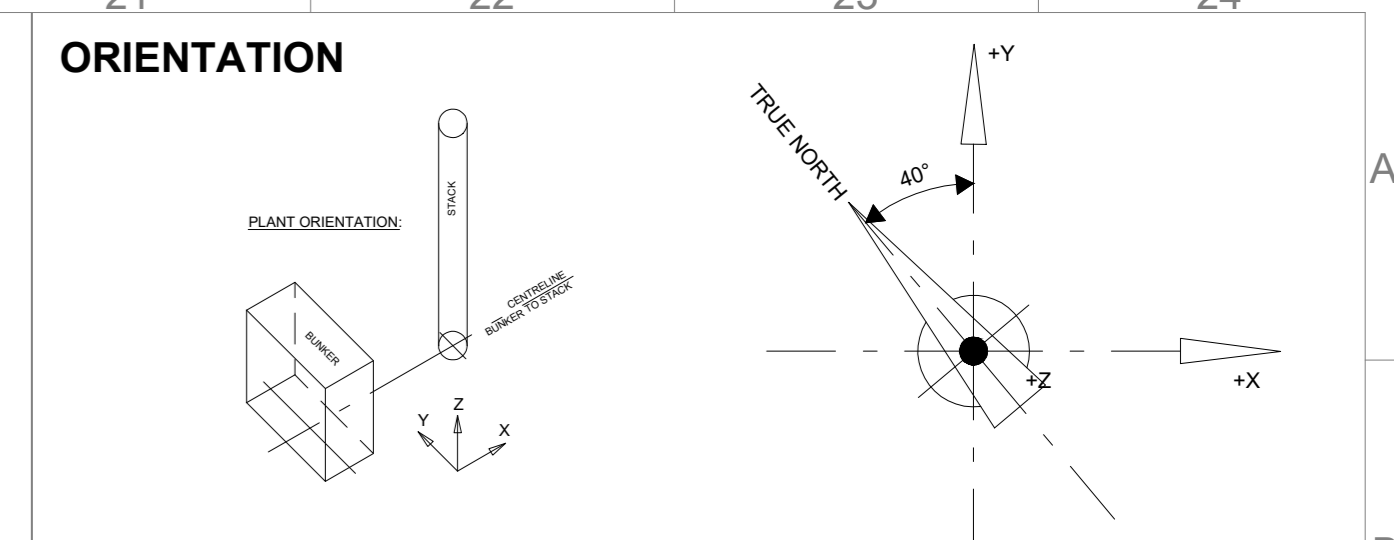
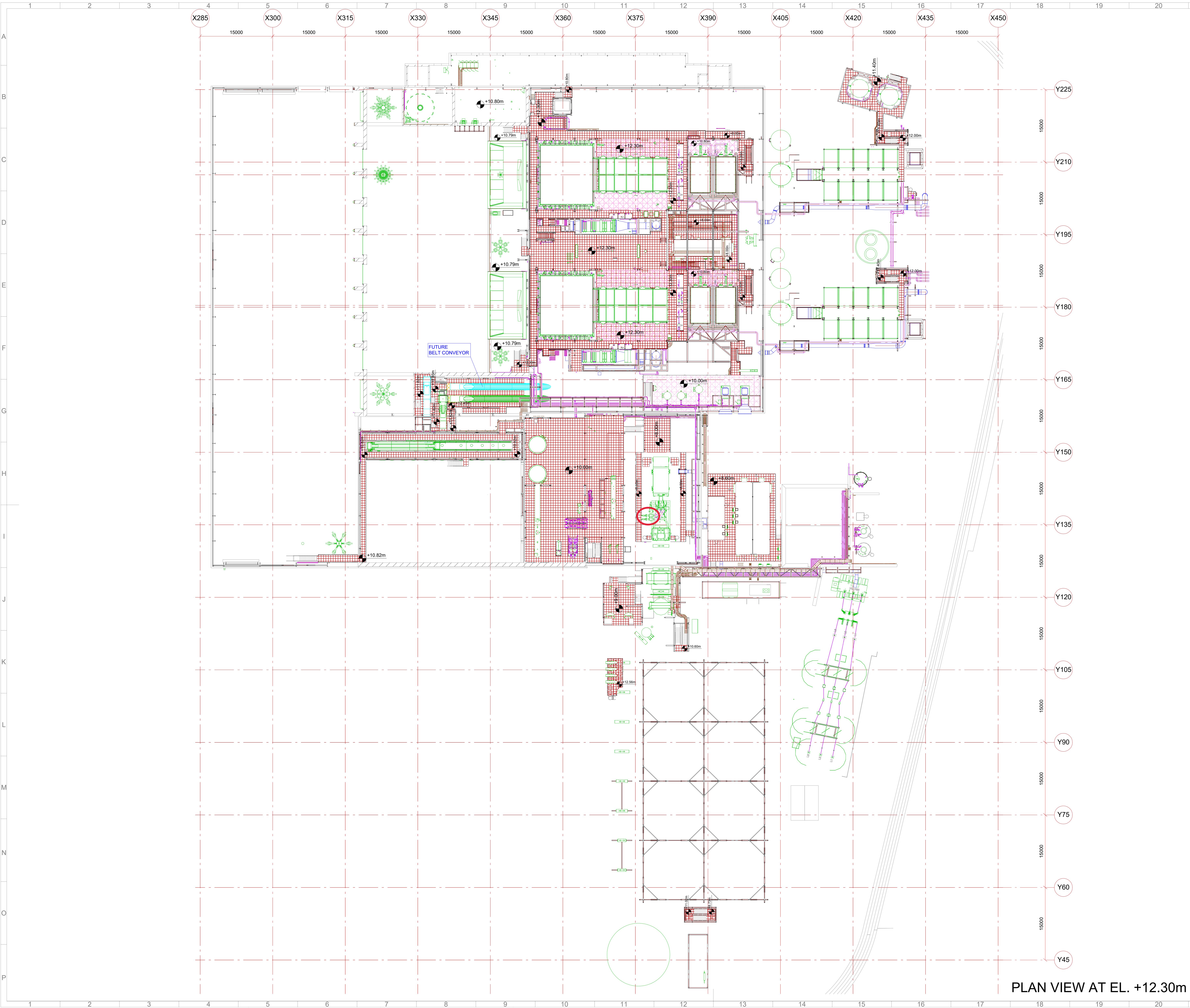

NOTES AND SYMBOLS

- ALL DIMENSIONS IN mm
- ALL LEVELS IN m REFERRING TO FINISHED FLOOR LEVEL (FFL) ±0.00m
- PLANT ORIGIN

X=0mm Y=0mm
CORRESPONDING TO SITE COORDINATES
E=581995370mm N=220544758mm

PLANT FINISHED FLOOR LEVEL (FFL) ±0.00m = +30.0m AOD
BUNKER/BOILER FINISHED FLOOR LEVEL (FFL) -12.00m = +18.0m AOD
BOILER/OT FINISHED FLOOR LEVEL (FFL) ±0.00m = +30.0m AOD
TIPPING HALL/ACC FINISHED FLOOR LEVEL (FFL) +05.00m = +35.0m AOD

- ALL DIMENSIONS AND LAYOUTS ARE ILLUSTRATIVE

TOP ... TOP OF PLATFORM
TOS ... TOP OF STEEL
BOS ... BOTTOM OF STEEL
FFL ... FINISHED FLOOR LEVEL
TOC ... TOP OF CONCRETE

CHECKER PLATE GRATING SAFEDECK

REFERENCE DOCUMENTS

BS00 - SITE OVERVIEW	LD010-HZI-40368410
BS00 - BUILDING SECTIONS	LD010-HZI-40368411

Illustrative Plan

Created by: Quod (on behalf of Indaver)

Indaver Rivenhall Ltd
Edinburgh Way
CM20 2NQ
Essex
UK

November 2023

PLAN VIEW AT EL. +12.30m

